

GRID3C—Computer Program for Generation of C-Type Multilevel, Three-Dimensional, Boundary- Conforming Periodic Grids

Djordje S. Dulikravich
Universities Space Research Association
Columbia, Maryland 21044

March 1982

Prepared for the
NATIONAL AERONAUTICS AND SPACE ADMINISTRATION
Lewis Research Center
Under Contract NAS3-22532

GRID3C – Computer Program for Generation of C-Type Multilevel, Three-Dimensional, Boundary-Conforming Periodic Grids

Djordje S. Dulikravich*

Universities Space Research Association
Columbia, Maryland 21044

Summary

A fast computer program, GRID3C, has been developed for accurately generating periodic, boundary-conforming, three-dimensional, consecutively refined computational grids applicable to realistic axial turbomachinery geometries. The method is based on using two analytic functions to generate two-dimensional grids on a number of coaxial axisymmetric surfaces positioned between the centerbody and the outer radial boundary. These boundary fitted grids are of the C-type and are characterized by quasi-orthogonality and geometric periodicity. The built-in nonorthogonal coordinate stretchings and shearings cause the grid clustering in the regions of interest. The stretching parameters are part of the input to GRID3C. In its present version GRID3C can generate and store a maximum of four consecutively refined three-dimensional grids. The output grid coordinates can be calculated either in the Cartesian or in the cylindrical coordinate system.

Introduction

When solving nonlinear partial differential equations governing fluid flow, exact boundary conditions should be applied on all boundaries. This requirement is easily met with a grid generated by the computer program GRID3C, which creates a three-dimensional C-type grid conforming to an irregularly shaped blade (or wing), hub (or fuselage), and duct (or outer radial boundary or wind tunnel wall).

Three-dimensional boundary-conforming grids for cascades of blades (as well as for the single wing-body combination) can be generated by a variety of methods (ref. 1). The method used in the present work (ref. 2) has the distinct advantage of being very fast and easy to understand. It is based on two conformal mapping functions (ref. 3) and on several additional simple analytical relations that perform coordinate stretchings and shearings. The general concept is similar to an earlier work on developing three-dimensional grids of an O-type (refs. 1 and 4).

*Presently Assistant Professor of Aerospace Engineering and Engineering Mechanics, The University of Texas at Austin.

The Computational Fluid Mechanics Branch of the NASA Lewis Research Center provided computational facilities used in this work. Dr. Charles Putt of the Computer Services Division was especially helpful in obtaining the three-dimensional plots.

Applicability of the Computer Program

Computer program GRID3C is capable of generating x, y, z or x, θ, r coordinates of a maximum of four consecutively refined boundary-conforming grids for any of the following three-dimensional configurations:

- (1) Arbitrarily shaped wing midmounted on an axisymmetric fuselage: This wing-body combination can be in free air or centrally positioned in a wind tunnel having a doubly infinite axisymmetric wall.
- (2) Propeller-type (usually referred to as "horizontal axis") windmill rotor having an arbitrary number of arbitrarily shaped blades mounted on an axisymmetric hub
- (3) Helicopter rotor
- (4) Propeller (prop-fan) for aircraft propulsion: The propeller can be in free air or centrally positioned in an axisymmetric wind tunnel.
- (5) Axial turbomachinery stator
- (6) Axial turbomachinery rotor
- (7) Ducted fan with rotor diameter smaller than the duct diameter
- (8) Propeller for marine propulsion: The propeller can be either free or ducted.

In the case of a turbomachinery stator, rotor, or ducted fan the outer radial boundary represents the surface of a duct or shroud. In the remaining text this surface is referred to as a duct. In the case of a free propeller, a helicopter rotor in hover, or a wing-body combination the outer radial boundary represents an arbitrarily axisymmetrically shaped surface positioned off the blade tip.

It is important to note that both the hub (or centerbody) and the duct (wind tunnel wall or outer radial boundary) can have different axisymmetric shapes. The number of blades is theoretically arbitrary, although GRID3C has certain limitations, which are explained in the following section. Each blade can be defined by as many as 43 different local

airfoil sections. The general blade (or wing) can incorporate an arbitrary spanwise distribution of chord length, thickness, twist angle, sweep angle, and dihedral angle. GRID3C is equally applicable to blades (or wings) with blunt (or rounded), wedged, and cusped trailing and/or leading edges. The trailing edge can be open or closed and the grid will conform with the approximate wake shape.

Note that in the case of a wing-body combination or a propeller the local airfoil shapes at the off-tip locations do not have to be specified in the input to GRID3C. This spanwise extension of the blade shape off the tip will be performed automatically by the code while keeping the same gap-to-chord ratio and airfoil shape as specified at the blade (or wing) tip location.

Limitations of the Computer Program GRID3C

Computer program GRID3C has several limitations. They are the following:

(1) All geometric parameters defining the blade shape must vary smoothly in the spanwise direction.

(2) The hub and shroud are doubly infinite. If the actual hub has a finite length, it must be specified as having thin "stings" extending from the end points toward the axial infinities.

(3) The hub and shroud radii must vary smoothly in the direction of the axis of rotation.

(4) The blade tip chord length must have a nonzero value.

(5) The maximum number of blades is limited by the fact that the minimum local value of the gap-to-chord ratio at any spanwise station must be greater than approximately $(h/c)_{\min} \geq 0.65$, where h is the arc length spacing between the blades and c is the local blade chord length. This limiting ratio is higher if the blade sections are highly staggered or the airfoils have higher camber and relative thickness. The maximum number of blades NB can be *a priori* estimated as

$$NB \leq 2\pi \left(\frac{r}{c}\right) \frac{1}{(h/c)_{\min}}$$

where r is radial distance from the axis of rotation.

(6) The maximum absolute value of the local stagger angle (angle between chord line and meridional plane) for typical axial compressor blades is limited in GRID3C to $|\beta|_{\max} \leq 65^\circ$. The value of $|\beta|_{\max}$ can be considerably larger ($|\beta|_{\max} \approx 90^\circ$) in the outer portions of wind turbine blades or propellers where (h/c) is also very large. In an axial gas turbine blade row, $|\beta|_{\max}$ will be lower because of the low values of $(h/c)_{\min}$ and the high camber and relative thickness.

(7) GRID3C does not allow for the existence of part-span dampers between blades.

(8) Besides blades, hub, and shroud, no other solid boundaries may be present in the flow field.

A disadvantage of the present method is that it is not applicable for very thick, highly twisted and cambered blades that are very closely spaced.

Grid-Generating Concept

When analyzing any of the configurations mentioned in the section on applicability, it is sufficient to consider a single rotationally periodic segment of the flow field (fig. 1). This segment is a doubly infinite periodic volume stretching in the direction of the axis of rotation. The volume has a constant angular width of $360^\circ/NB$, where NB is the total number of blades. The blades have arbitrary spanwise distributions of taper, sweep, dihedral, and twist angles. The local airfoil shapes can vary in an arbitrary fashion along the blade span. The rotor hub and the duct (or shroud) can have different arbitrary axisymmetric shapes. Such an arbitrary three-dimensional physical domain is first discretized in the spanwise direction by a number of coaxial axisymmetric surfaces that are, in general, spaced between the hub and the shroud. Each of these surfaces is then discretized.

The major problem in generating and discretizing the axisymmetric surfaces is an accurate determination of the intersection contours between the irregular blade surface and the coaxial axisymmetric surfaces cutting the blade. The coordinates of the points on these contours are defined by fitting cubic splines along the blade and interpolating at the radial stations corresponding to each axisymmetric surface (ref. 2).

Once the shape of the intersection contour on a particular cutting axisymmetric surface is known, the problem becomes one of discretizing a doubly connected two-dimensional domain (fig. 2). Such a two-dimensional domain is mapped conformally on a unit circle (fig. 3) with the analytic function (ref. 3)

$$z = z_s + \frac{h}{NB} e^{i\beta} [2\beta \sin \beta + 2 \cos \beta \ln(2 \cos \beta)] \\ + e^{-i\beta} (\ln \bar{w} - i\pi) - 2 \cos \beta (1 - \bar{w})$$

The unit circle is "unwrapped," with the second analytic function (ref. 3)

$$\bar{w} = \tanh \left(\frac{\xi^2}{2} \right)$$

Resulting is a deformed rhomboidal shape that is then nonorthogonally sheared in the horizontal and vertical directions to give a rectangular X, Y computational domain (fig. 4). A uniform grid in the X, Y plane that is symmetrically spaced with respect

to the Y axis remaps back into the physical plane as a C-type boundary-conforming grid (fig. 5). The actual radial coordinates are obtained by fitting cubic splines along the C-type grid lines and interpolating at a number of axial stations at which the radius of the corresponding axisymmetric surface is known.

Computer Program

General Description

The computer program GRID3C consists of a main program (fig. 6) and four subroutines. Input to GRID3C is accomplished by a separate deck of cards, which will be discussed in detail in the following section. Parts of the output from GRID3C appear in standard computer printout form; the major portion of the output (representing coordinates of each grid point) is automatically written on tapes or disks (units 11, 12, 13, and 14).

The main program reads all input data and determines coordinates of the intersection contours created by the axisymmetric computational surfaces and the blade surface. This is performed by fitting cubic splines (subroutine SPLIF) along the blade span and interpolating (subroutine INTPL) at desired radial stations (ref. 2). The intersection contour on each axisymmetric surface is expressed in sheared cylindrical coordinates and iteratively mapped by using subroutine TRANSF onto a deformed unit circle. Subroutine TRANSF "unwraps" the circle with the semisplit. The resulting deformed rhomboidal shape is then transformed into a parallelepipedal shape by using nonorthogonal coordinate stretching and shearing in both coordinate directions. Subroutine TRANSF maps points back into the sheared axisymmetric surface. Coordinates of the resulting body-conforming grid on each periodic strip are then interpolated on their respective axisymmetric surface. Subroutine XYZINF suitably shapes grid cells at axial infinity cutoff boundaries. XYZINF also generates periodic and imaginary grid points (fig. 7). Finally, x, y, z or x, θ, r coordinates are written on disks or tapes numbered unit 11, 12, 13, and 14.

Input

An example of the entire input to GRID3C, in card form, is shown in figure 8. The first card is the title card on which the user can write as many as 80 alphanumeric characters (fig. 9) specifying the name of the input deck. This text will also appear on the output listing from GRID3C.

The second card contains:

NB number of blades. The minimum value is NB = 2.

NX number of grid cells to be generated on the blade surface, that is the number of grid cells

on the first (coarse) grid in the direction of the computational X axis. Suggested value is NX = 20. Users of GRID3C should remember that NX must be an even number. The maximum value for NX is 160.

NY number of grid cells to be generated in the computational Y direction, that is, the number of C-layers of grid cells around the blade on the first (coarse) grid. Suggested minimum value is NY = 5. It is advisable to specify the value of NY from the following relation:

$$NY = NX/4$$

The maximum value is NY = 40. The number of grid cells between the trailing edge and the downstream infinity (wake cells) is automatically assumed as equal to NY. Hence, the total number of grid cells on any C-layer is

$$NXX = NX + 2 \cdot NY$$

NZ number of grid cells to be generated in the spanwise direction (computational Z direction) from the hub to the outer radial boundary on the first (coarse) grid. The shape and radial distance of the outer boundary surface will be specified later in the input. The maximum value is NZ = 40

NT number of grid cells to be generated in the spanwise direction from hub to tip on the first (coarse) grid. The value of NT should be

$$NT \leq NZ - 3$$

NT is equal to NZ only when r_t is equal to the radius of the outer boundary, where r_t is the rotor radius.

NH number of input points defining hub and sting surface. The maximum value for NH is 43.

ND number of input points defining duct (or outer radial boundary) surface. The maximum value for ND is 43. ND must be equal to or less than NH.

NP number of input planes. The maximum value is NP = 43 (fig. 10).

NG number of grids to be generated. If NG = 1, only the coarse three-dimensional grid consisting of (NXX * NY * NZ) grid cells will be generated and its x, y, z (or x, θ, r) coordinates permanently stored on unit 11. If NG = 2, this coarse grid will be automatically refined by doubling the number of grid cells in each of three computational directions. Coordinates of this refined (second) grid will then be written on unit 12, but the coordinates of the coarse (first) grid will remain stored on unit 11. If

NG = 3, the second grid will also be refined in the same manner as was the first grid. The coordinates of this fine (third) grid will then be written on unit 13. If NG = 4, the same procedure will be repeated, and the coordinates of the fourth (final) grid will be written on unit 14. Users of GRID3C should be aware of the computer storage requirements resulting from the successive grid refinement procedure (fig. 11). The present version of GRID3C is capable of automatically generating coordinates for as many as four (NG = 4) refined grids, the fourth grid having a maximum of $240 \times 40 \times 40$ grid cells. These values can be changed by changing COMMON and DIMENSION statements.

- NC coordinate system preference index. If NC = 1 output coordinates will be Cartesian (x, y, z). If NC = 0 output coordinates will be cylindrical (x, θ, r).
- XX X coordinate stretching parameter (ref. 2). If XX = 1.0 grid points on the blade surface will be equidistantly spaced with respect to the blade surface arc length. If XX > 1.0 the grid points will be symmetrically clustered closer to the leading edge and the trailing edge. The input value for XX must be in the region

$$1.40 > XX \geq 1.0$$

- YY Y coordinate stretching parameter (ref. 2). If YY = 1.0 the C-type grid layers will be mildly clustered towards the blade surface. If YY > 1.0 the C-type grid layers will be clustered closely to the blade surface and the wake. The suggested value is

$$1.05 \geq YY \geq 0.95$$

- ZZ Z coordinate stretching parameter (ref. 2). If ZZ = 0.0 the axisymmetric computational surfaces will be equidistantly spaced in the axial direction. If ZZ > 0.0 these surfaces will be symmetrically clustered closer to the hub surface and the blade tip region. The suggested value is

$$0.75 \geq ZZ \geq 0.0$$

- DZ length scaling coefficient. DZ multiplies all output length coordinates generated by GRID3C program.

Input length units	Output length units	DZ
meters	meters	1.000
feet	feet	1.000
feet	meters	0.3048
meters	feet	3.2808

- RT rotor radius, or wing half span r_r , length.
- SA setting (pitch) angle of the blade, deg. SA represents the constant angle that will be automatically added to the local stagger (twist) angle at each spanwise input station when generating a sequence of grids for a variable-pitch rotor (or stator). Each time it is necessary to change the value of SA only; the rest of the input should stay the same.
- XE distance between the blade trailing edge and the downstream boundary of the flow domain. XE is expressed in average blade chord lengths.

A number of the following input cards (card 4 to card m in fig. 9) specify hub and duct geometry. Each of these input cards lists the following values:

- x_h x coordinate of the input point on the hub or sting surface
- r_h r coordinate of the input point on the hub or sting surface
- x_d x coordinate of the input point on the outer radial boundary
- r_d r coordinate of the input point on the outer radial boundary

Hub and shroud surfaces should be defined at least a distance of $(2\pi/NB)r_d$ upstream of the rotor.

Blade geometry is defined on NP parallel input planes (fig. 10), where the first input plane ($N = 1$) must be entirely inside the hub and the last input plane must be entirely at or beyond the shroud surface or outer radial boundary surface.

The following input card (card $m + 1$ in fig. 9) contains geometric parameters specifying the first input plane ($N = 1$). These parameters are

- ZL z coordinate of the blade leading edge on the N^{th} input plane (fig. 10)
- XL x coordinate of the blade leading edge on the N^{th} input plane (fig. 10). The origin of the x, θ, r coordinate system is arbitrarily positioned on the x axis. Blade stacking axis corresponds to z axis (or r axis).
- YL y coordinate of the blade leading edge on the N^{th} input plane (fig. 10).
- CH chord length (not the projected chord length) of the blade on the N^{th} input plane (fig. 12). Although the chord length is always a positive number, the value of CH can be assigned a negative sign, thus indicating if a single airfoil shape is to be used for the blade design. If CH > 0 on the N^{th} input plane, the airfoil shape on the $(N + 1)^{\text{th}}$ input plane is the same as it was on the N^{th} input plane. If CH < 0, the airfoil shape on the $(N + 1)^{\text{th}}$ input plane is different from the airfoil shape on the N^{th} input plane (fig. 13).

- TW angle between the blade chord on the N^{th} input plane and the x axis (fig. 12), deg. TW is positive on figure 12.
- IPNT number of input points defining airfoil shape on N^{th} input plane. The input points are given in the clockwise direction starting from the trailing-edge point. If the airfoil shape is non-symmetric, IPNT must be an even number (counting the trailing-edge point twice). If the airfoil shape is symmetric, IPNT must be an odd number, and only coordinates of points on the lower surface of the airfoil should be specified. The value of IPNT can vary from one N^{th} plane to the next. Maximum number is IPNT = 167.

The following set of input cards (card $m + 2$ to card n in fig. 9) specifies the x' and y' input coordinates (fig. 12) defining the airfoil shape on the N^{th} input plane. The origin of the x', y' coordinate system is arbitrarily positioned with respect to the airfoil leading edge (fig. 12). The input coordinates x' and y' do not have to be normalized with respect to the chord length. Scalings, rotation, and translation of the input coordinates will be performed automatically by the GRID3C program. The coordinate axis x' does not have to be parallel with the x coordinate axis, but it must be in the N^{th} input plane.

All the x' coordinates are specified in the input separately, followed by all the y' coordinates (figs. 8 and 13). The number of x' (or y') coordinates that can be specified on each input card is eight (fig. 9). If the total number of input points (IPNT) is not a multiple of eight, the remainder of the last input card of a set specifying x' coordinates (as well as the last card specifying y' coordinates) should be filled with the values $x' = 0$ (or $y' = 0$).

This concludes all the input data needed for the N^{th} input plane.

The $(N + 1)^{\text{th}}$ input plane and the airfoil shape are defined on the following set of input cards, starting with card $n + 1$ in figure 9. These cards are identically formatted as are the cards from $m + 1$ to n (fig. 9). If $CH > 0$ on card $m + 1$, the $(N + 1)^{\text{th}}$ input plane will be defined by a single input card having the format of card $m + 1$, as can be seen in figure 13.

Output

Parts of the output of GRID3C will appear in printed form and require approximately three pages of computer printout (fig. 14). The main result of GRID3C are coordinates of three-dimensional body-conforming grids (or grid, if $NG = 1$). The coordinates of the coarse (first) grid will be automatically written on tape (or disk) unit 11. If $NG = 2$ in the input data, coordinates of the second (refined) grid will be written on unit 12; and if $NG = 3$, the coordinates of the third (fine) grid will be

written on unit 13. If $NG = 4$, the coordinates of the fourth (final) grid will be written on unit 14. This storage arrangement provides the user with an opportunity to display and analyze each grid separately. All the WRITE statements are unformatted and could be found in the main program.

The output listing specifies the data contained on the first m input cards as well as each $(m + 1)^{\text{th}}$ card. This serves for easier detecting of errors that may have been made during the preparation of the input.

The output from GRID3C continues with a listing of the following parameters defining airfoil shapes on each of the K computational axisymmetric surfaces (fig. 14).

- XLEAD x coordinate of blade leading edge on K^{th} surface
- ZLEAD z coordinate of blade leading edge on K^{th} surface
- YLEAD y coordinate of blade leading edge on K^{th} surface
- CHORD chord length of blade (side projection on x - z plane) on K^{th} surface

$$\text{CHORD} = [(y_{TE} - y_{LE})^2 + (x_{TE} - x_{LE})^2]^{1/2}$$

- TWIST angle between blade chord on K^{th} surface (side projection on x - z plane) and axis of rotation, deg

$$\text{TWIST} = \sin^{-1}[(y_{TE} - y_{LE})/\text{CHORD}]$$

- K label (index) number of particular computational axisymmetric surface generated by GRID3C. The parameter K varies from $K = 2$ (hub surface) to $K = NZ * NG + 2$ corresponding to the duct or outer radial boundary surface

Thus the total number of axisymmetric computational surfaces that will be generated and stored on, for example, tape 14 is

$$\text{MAXZM} = \text{NZ} * 4 + 1$$

Because subroutine XYZINF generates a layer of imaginary points inside the blade and the wake ($J = \text{MAXYP}$) as well as one layer ($J = 1$) of points off the periodicity (fig. 7) boundaries ($J = 2$), the total number of C-type layers of points generated on each K^{th} axisymmetric surface is

$$\text{MAXYP} = \text{NY} * \text{NG} + 3$$

Similarly, GRID3C generates grid points on the vortex sheet or wake trailing from the blade trailing edge (fig. 7). GRID3C also generates two lines ($I = 1$ and $I = \text{MAXXP}$) of points off the downstream infinity. Hence the total number of points generated on each C-type layer is

$$\text{MAXXP} = \text{NXX} * \text{NG} + 3$$

As a consequence, tape 11 will contain coordinates of $(\text{NXX} + 3) * (\text{NY} + 3) * (\text{NZ} + 1)$ grid points, tape 12 will contain coordinates of $(\text{NXX} * 2 + 3) * (\text{NY} * 2 + 3) * (\text{NZ} * 2 + 1)$ grid points, tape 13 will contain coordinates of $(\text{NXX} * 3 + 3) * (\text{NY} * 3 + 3) * (\text{NZ} * 3 + 1)$ grid points, and tape 14 will contain coordinates of $(\text{NXX} * 4 + 3) * (\text{NY} * 4 + 3) * (\text{NZ} * 4 + 1)$ grid points. These coordinates are written on corresponding tapes in a single-precision unformatted form.

To assure the user of GRID3C that each grid was stored on its corresponding tape or disk, the following output control parameters are printed after grid was generated on each K^{th} surface:

NTAPE tape (or disk) unit number on which the appropriate grid from K^{th} surface was stored

MAXXP, total number of grid points (MAXXP * MAXYP) extracted from the finest grid on K^{th} surface and stored on tape with the unit number NTAPE

Elements of a three-dimensional C-type periodic grid generated by GRID3C code for a simple wing-body combination (fig. 8) are shown in figure 15.

Note that the physical wing is rectangular. Its extension in the off-tip region is automatically generated by GRID3C while keeping the gap-to-chord ratio the same as at the wing tip location. For clarity reasons only one of the axisymmetric (in this

case cylindrical) surfaces is shown, and the intersection contours of other surfaces with the wing surface are indicated. Figures 16 and 17 represent the discretized blade surface and the hub surface of an eight blade advanced NASA prop-fan configuration. Note the fact that in this case the hub has a variable radius.

References

1. Numerical Grid Generation Techniques. NASA CP-2166, 1980.
2. Dulikravich, D. S.; Fast Generation of Three-Dimensional Computational Boundary Conforming Periodic Grids of C-Type. Symposium on Numerical Generation of Curvilinear Coordinate Systems and Use in the Numerical Solution of Partial Differential Equations, Nashville, Tenn., April 13-16, 1982. (Also NASA CR-165596, 1982; also to appear as a paper in *Numerical Grid Generation*, edited by Joe F. Thompson, Elsevier North Holland, New York, 1982)
3. Sockol, P.; Generation of C-Type Cascade Grids for Viscous Flow Computation. Numerical Grid Generation Techniques. NASA CP-2166, 1980, pp. 437-448.
4. Dulikravich, D. S.; GRID30-Computer Program for Fast Generation of Multilevel, Three-Dimensional Boundary-Conforming O-Type Computational Grids. NASA TP-1920, 1981.

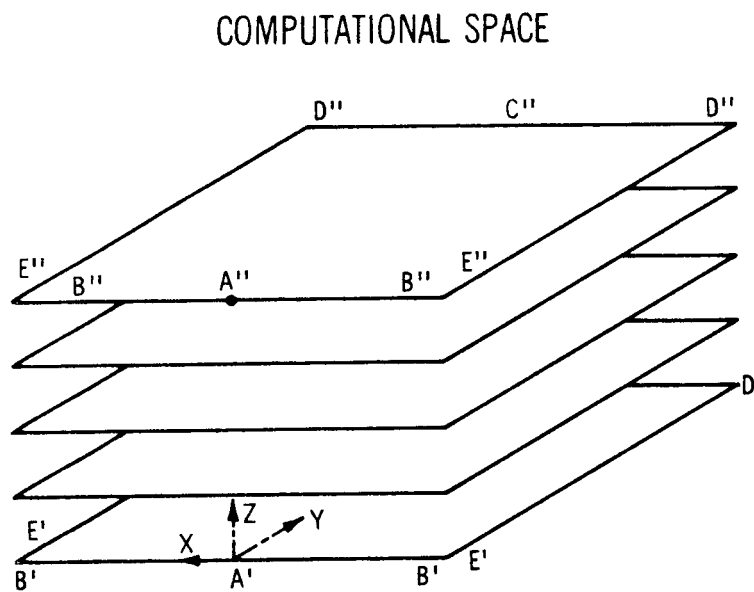
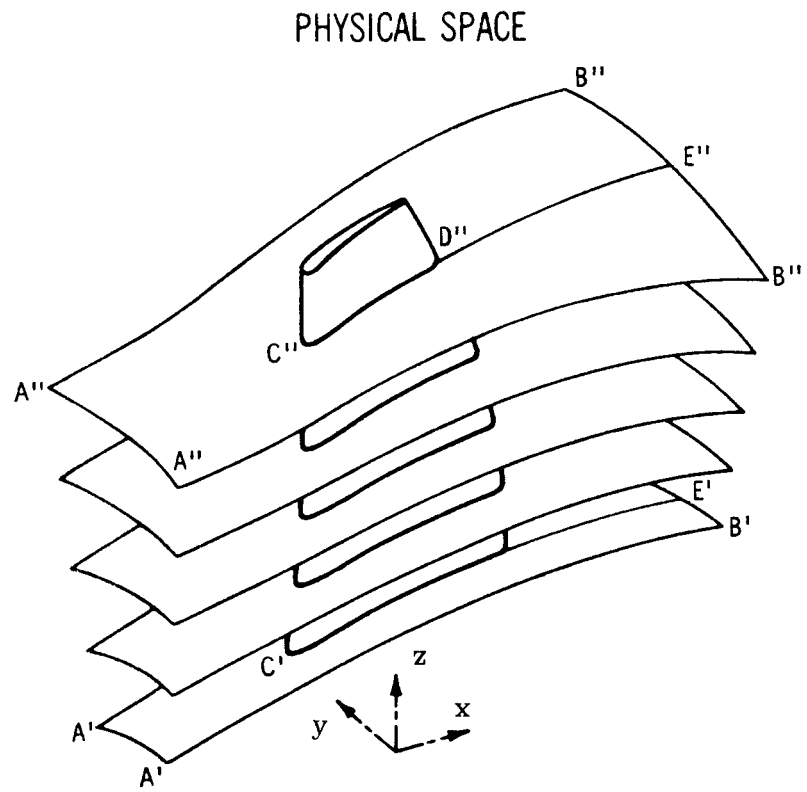

Figure 1. – Global transformation of a periodic three-dimensional flow domain from physical (x,y,z) into computational (X,Y,Z) space.

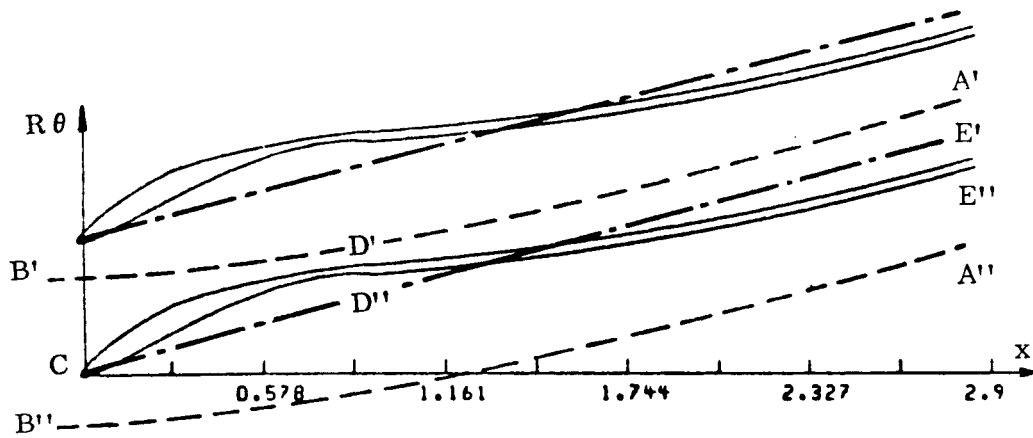

Figure 2. – Cascade of airfoils (with wakes) on (x, R, θ) computational axisymmetric surfaces. Cascade of semi-infinite slits and periodic boundaries are indicated.

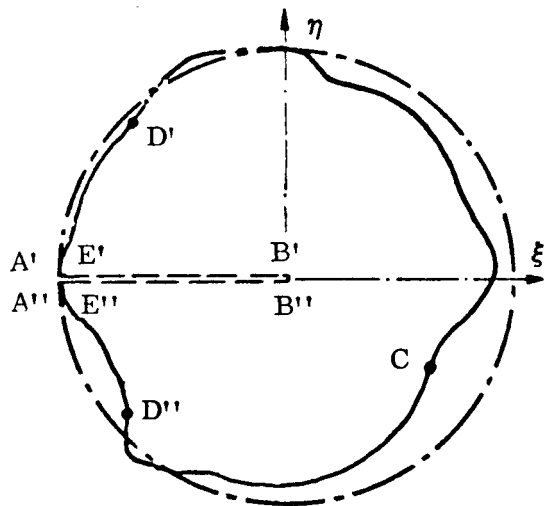

Figure 3 – Intermediate or “circle” plane obtained by conformally mapping a cascade of slits (— — —) and a cascade of airfoils (——) from figure 2.

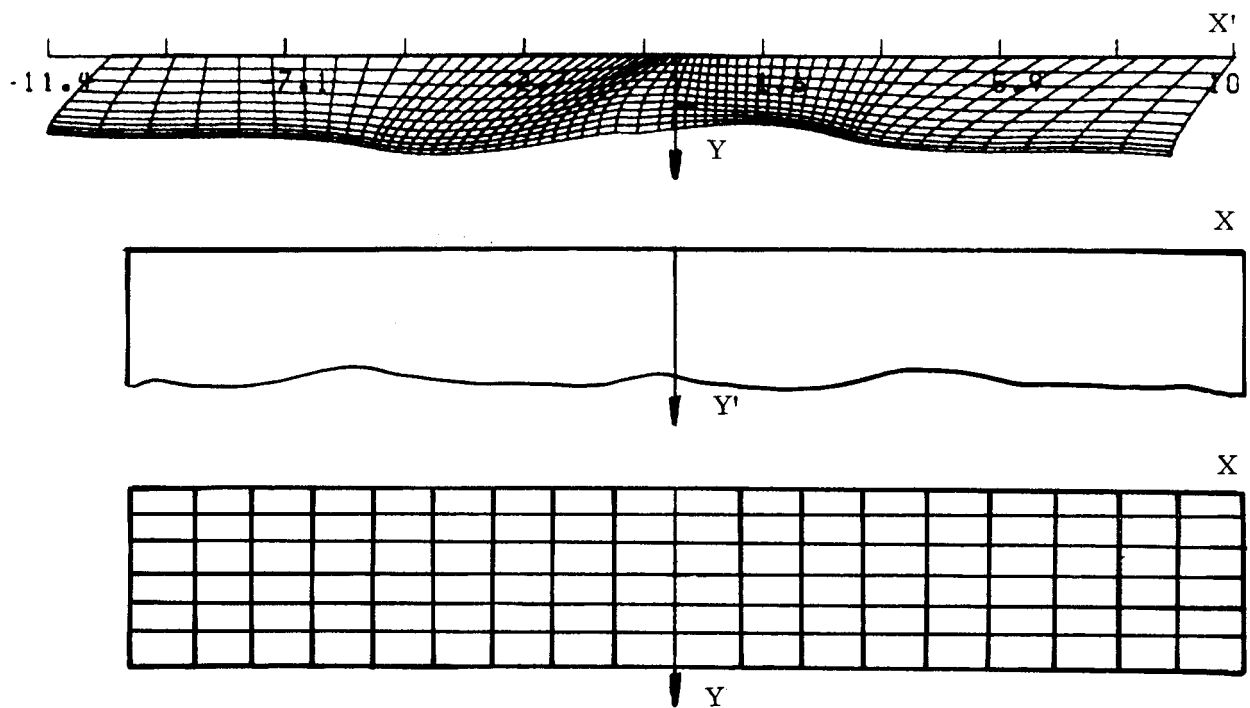

Figure 4. – Final or “strip” plane obtained by conformally mapping the “circle” plane (fig. 3). Indicated is also the effect of nonorthogonal coordinate shearing (normalization) in X and in Y coordinate directions.

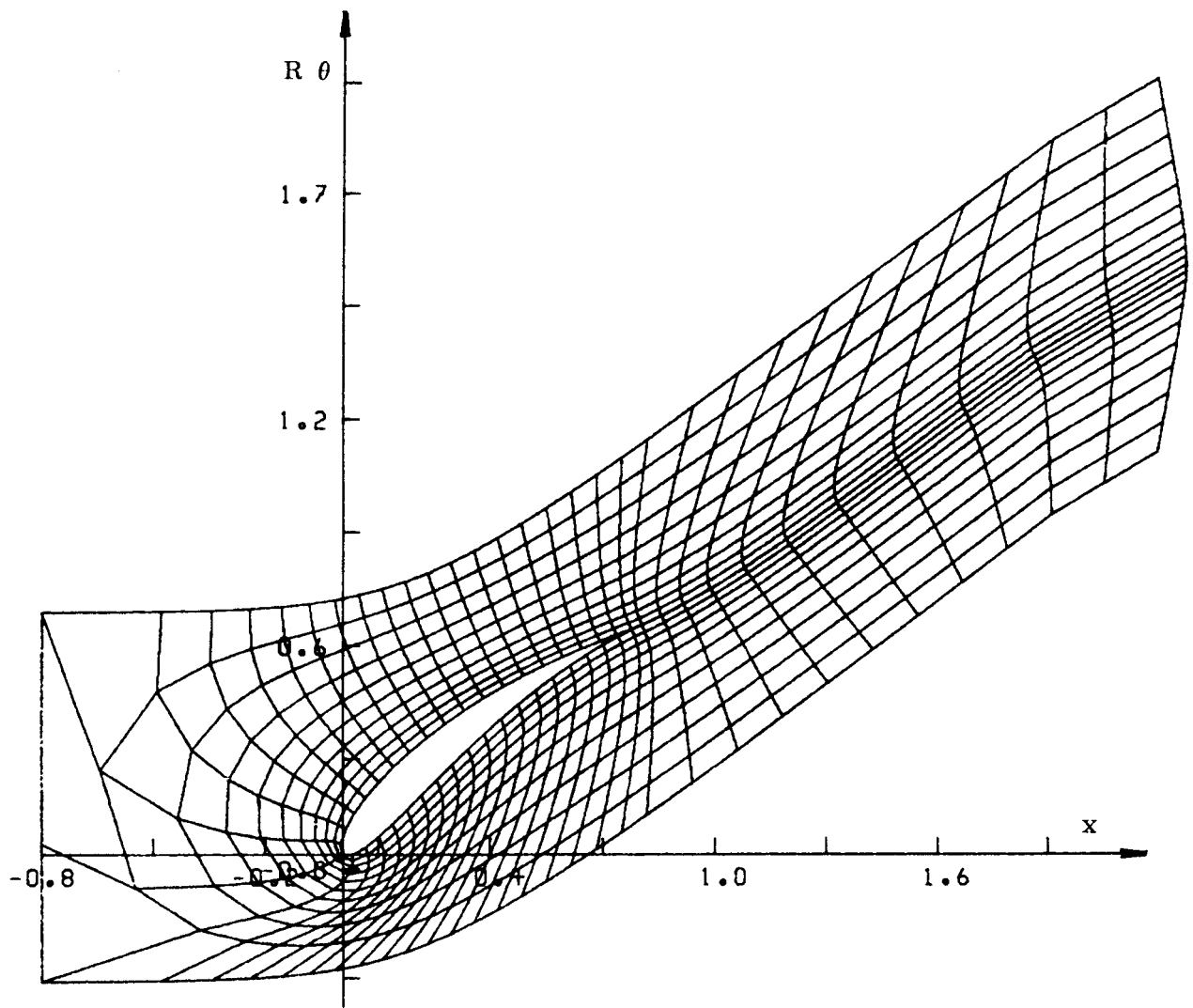

Figure 5. – General appearance of a remapped C-type grid on an (x,R,θ) axisymmetric surface.

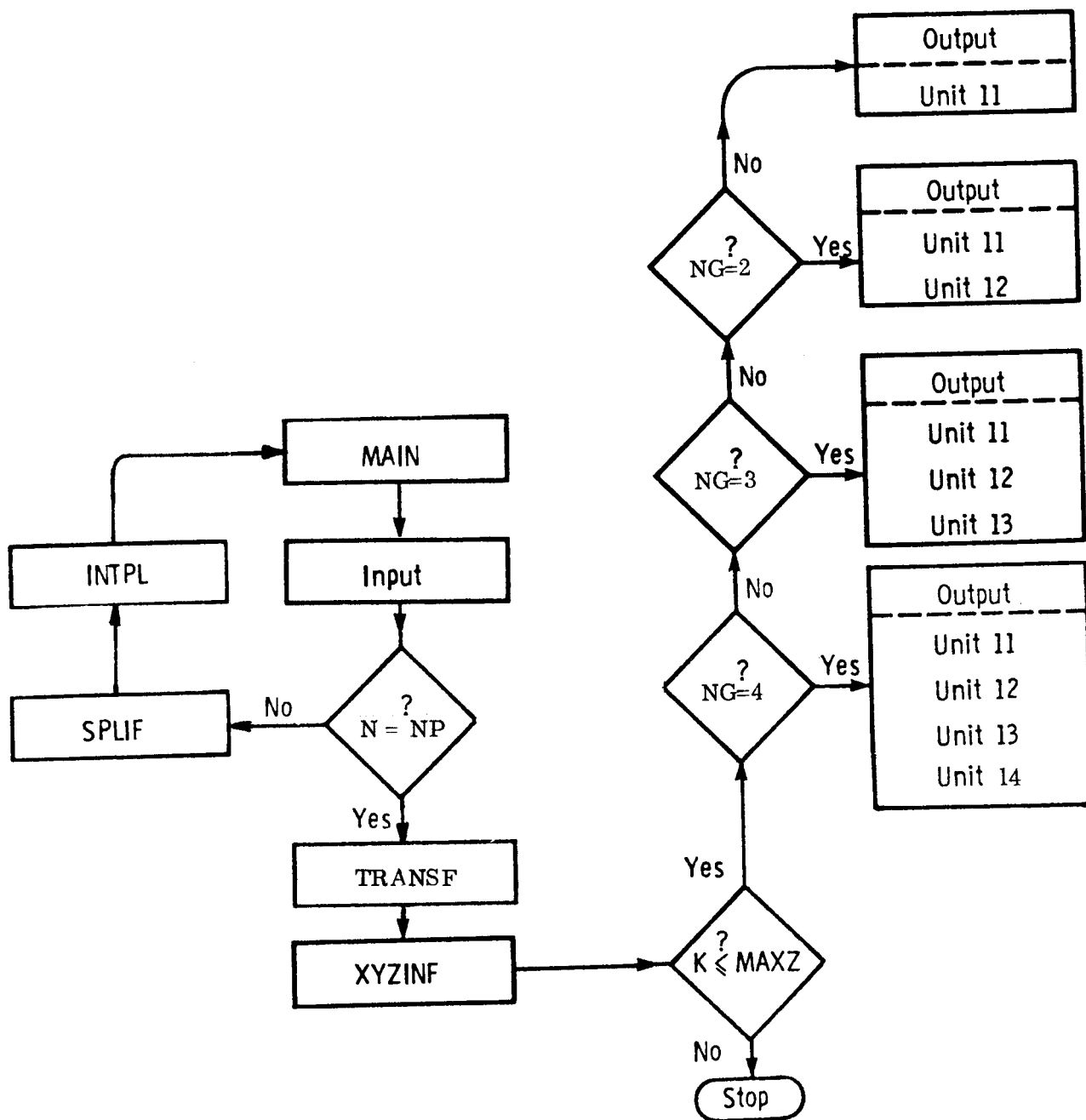

Figure 6. – Global flow chart for GRID3C computer code.

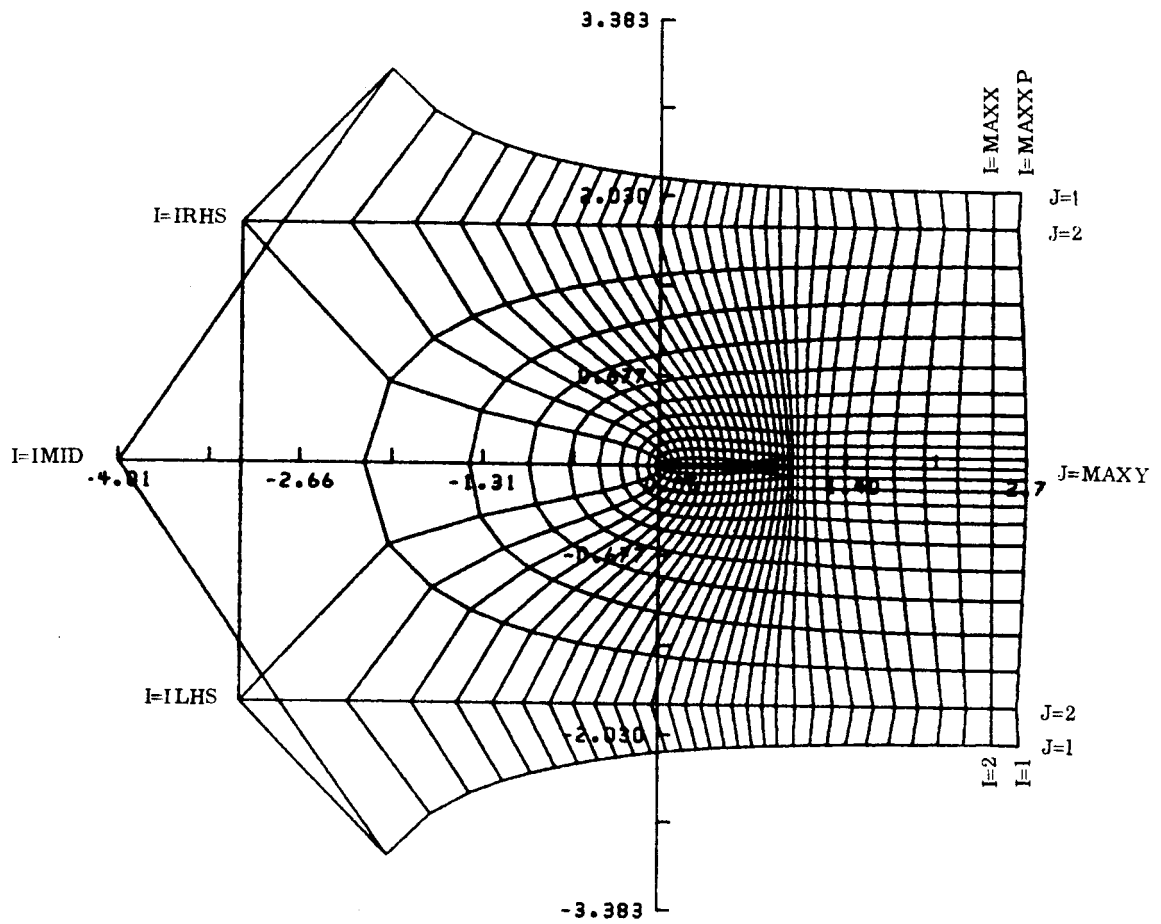

Figure 7. — An example of a complete C-type two-dimensional grid on each of the axisymmetric computational surfaces. Note the periodic layer ($J=1$) of points and the imaginary layer ($J=MAXYP$) of points. Also notice the columns ($I=1$ and $I=MAXXP$) of imaginary points at the downstream boundary. In actual flow calculations, grid point $I=IMID$ is omitted. Hence, its location is arbitrary.

```

RECTANGULAR NACA0012 WING MID-MOUNTED ON CYL. FUSELAGE : INPUT FOR (GRID3C)
NB= 2NX= 24NY= 6NZ= 8NT= 5NH=10ND=10NP=21NG=2NC=1
XX= 1.100YY= 1.000ZZ= 0.500DZ= 1.000RT= 3.000SA= 0.000XE= 1.500
-9.990000 0.150000 -9.990000 6.000000
-7.500000 0.150000 -7.500000 6.000000
-3.000000 0.150000 -3.000000 6.000000
-0.400000 0.150000 -0.400000 6.000000
0.000000 0.150000 0.000000 6.000000
0.200000 0.150000 0.200000 6.000000
0.500000 0.150000 0.500000 6.000000
1.000000 0.150000 1.000000 6.000000
5.000000 0.150000 5.000000 6.000000
12.500000 0.150000 12.500000 6.000000
0.050000 0.000000 0.000000 -0.500000 0.000000 0.000000 0.000000 1.000000 0.000000 64
1.000000 0.9911489 0.9886990 0.9861110 0.9832460 0.9799700 0.9761530 0.9716700
0.9664020 0.9602390 0.9530820 0.9448389 0.9354300 0.9247890 0.9128610 0.8996029
0.8849880 0.8690020 0.8516440 0.8329290 0.8128850 0.7915540 0.7689900 0.7452599
0.7204450 0.6946350 0.6679299 0.6404409 0.6122860 0.5835890 0.5544820 0.5250970
0.4955740 0.4660510 0.4366670 0.4075590 0.3788620 0.3507070 0.3232180 0.2965130
0.2707030 0.2458880 0.2221590 0.1995950 0.1782629 0.1582190 0.1395040 0.1221470
0.1061610 0.0915460 0.0782880 0.0663590 0.0557180 0.0463100 0.0380670 0.0309090
0.0247470 0.0194790 0.0149950 0.0111780 0.0079020 0.0050380 0.0024490 0.0000000
0.0000000 -0.0012490 -0.0015920 -0.0019530 -0.0023520 -0.0028060 -0.0033330 -0.0039490
-0.0046680 -0.0055040 -0.0064660 -0.0075640 -0.0088050 -0.0101910 -0.0117240 -0.0134020
-0.0152230 -0.0171780 -0.0192610 -0.0214590 -0.0237610 -0.0261500 -0.0286110 -0.0311250
-0.0336730 -0.0362340 -0.0387840 -0.0413010 -0.0437580 -0.0461310 -0.0483920 -0.0505150
-0.0524720 -0.0542360 -0.0557810 -0.0570840 -0.0581230 -0.0588790 -0.0593370 -0.0594860
-0.0593200 -0.0588380 -0.0580430 -0.0569460 -0.0555900 -0.0539030 -0.0520000 -0.0498760
-0.0475600 -0.0450840 -0.0424800 -0.0397810 -0.0370190 -0.0342250 -0.0314250 -0.0286450
-0.0259010 -0.0232000 -0.0205370 -0.0178790 -0.0151550 -0.0122020 -0.0085910 0.0000000
0.100000 0.000000 0.000000 0.500000 0.000000 0.000000 0.000000 1.000000 0.000000 64
0.250000 0.000000 0.000000 0.500000 0.000000 0.000000 0.000000 1.000000 0.000000 64
0.500000 0.000000 0.000000 0.500000 0.000000 0.000000 0.000000 1.000000 0.000000 64
0.750000 0.000000 0.000000 0.500000 0.000000 0.000000 0.000000 1.000000 0.000000 64
1.000000 0.000000 0.000000 0.500000 0.000000 0.000000 0.000000 1.000000 0.000000 64
1.500000 0.000000 0.000000 0.500000 0.000000 0.000000 0.000000 1.000000 0.000000 64
1.750000 0.000000 0.000000 0.500000 0.000000 0.000000 0.000000 1.000000 0.000000 64
2.000000 0.000000 0.000000 0.500000 0.000000 0.000000 0.000000 1.000000 0.000000 64
2.250000 0.000000 0.000000 0.500000 0.000000 0.000000 0.000000 1.000000 0.000000 64
2.500000 0.000000 0.000000 0.500000 0.000000 0.000000 0.000000 1.000000 0.000000 64
2.750000 0.000000 0.000000 0.500000 0.000000 0.000000 0.000000 1.000000 0.000000 64
3.000000 0.000000 0.000000 0.500000 0.000000 0.000000 0.000000 1.000000 0.000000 64
3.100000 0.000000 0.000000 0.500000 0.000000 0.000000 0.000000 1.000000 0.000000 64
3.250000 0.000000 0.000000 0.500000 0.000000 0.000000 0.000000 1.000000 0.000000 64
3.500000 0.000000 0.000000 0.500000 0.000000 0.000000 0.000000 1.000000 0.000000 64
4.000000 0.000000 0.000000 0.500000 0.000000 0.000000 0.000000 1.000000 0.000000 64
4.500000 0.000000 0.000000 0.500000 0.000000 0.000000 0.000000 1.000000 0.000000 64
5.500000 0.000000 0.000000 0.500000 0.000000 0.000000 0.000000 1.000000 0.000000 64
6.500000 0.000000 0.000000 0.500000 0.000000 0.000000 0.000000 1.000000 0.000000 64
8.500000 0.000000 0.000000 0.500000 0.000000 0.000000 0.000000 1.000000 0.000000 64

```

Figure 8. – Complete input for a geometry consisting of a doubly infinite circular cylinder and a midmounted, rectangular, unswept wing composed of NACA 0012 airfoil sections. The wing is at zero angle of attack. Note that only the lower wing surface points are specified because the airfoil is symmetric.

Card	Format
1	TITLE
	----- 20A4
2	NB, NX, NY, NZ, NT, NH, ND, NP, NG, NC
	----- 2(3X, I3), 6(3X, I2), 2(3X, I1)
3	XX, YY, ZZ, DZ, RT, SA, XE
	----- 7(3x, F7. 3)
4 to m	XHUB (I), RHUB (I), XDUCT (I), RDUCT (I)
	----- 4F10. 6
m + 1	ZL, XL, YL, CH, TW, XSI, YSI, XS2, YS2, IPNT, N
	----- 5F9. 5, 4F8. 5, I3
(m + 2) to n	x' (1), . . . , x' (8)
	----- 8F10. 7
n + 1	y' (1), . . . , y' (8)
	----- Same as m + 1
.	.
.	.
.	.

Figure 9. – General input format for GRID3C computer code.

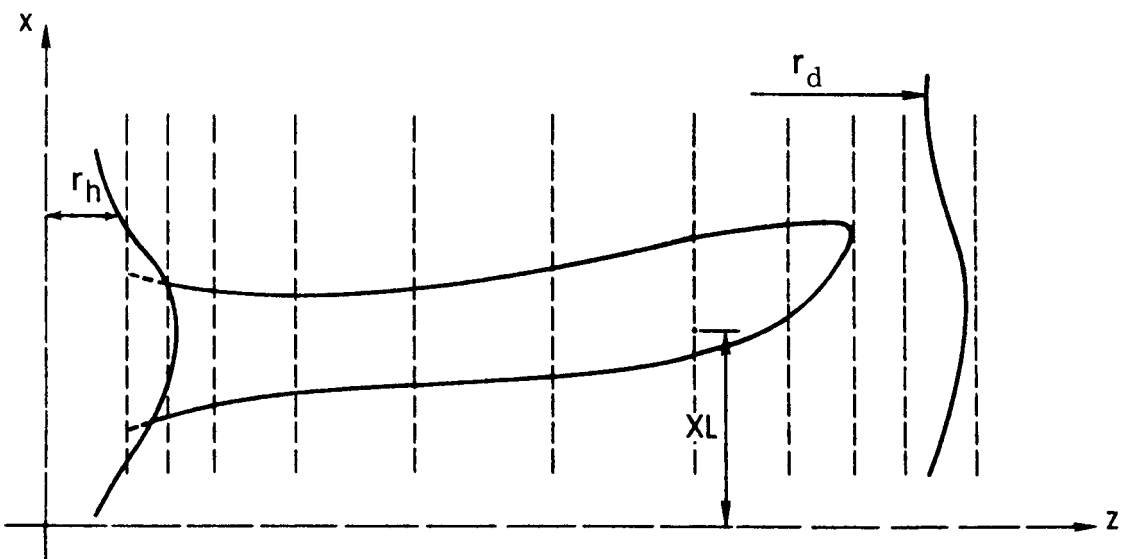
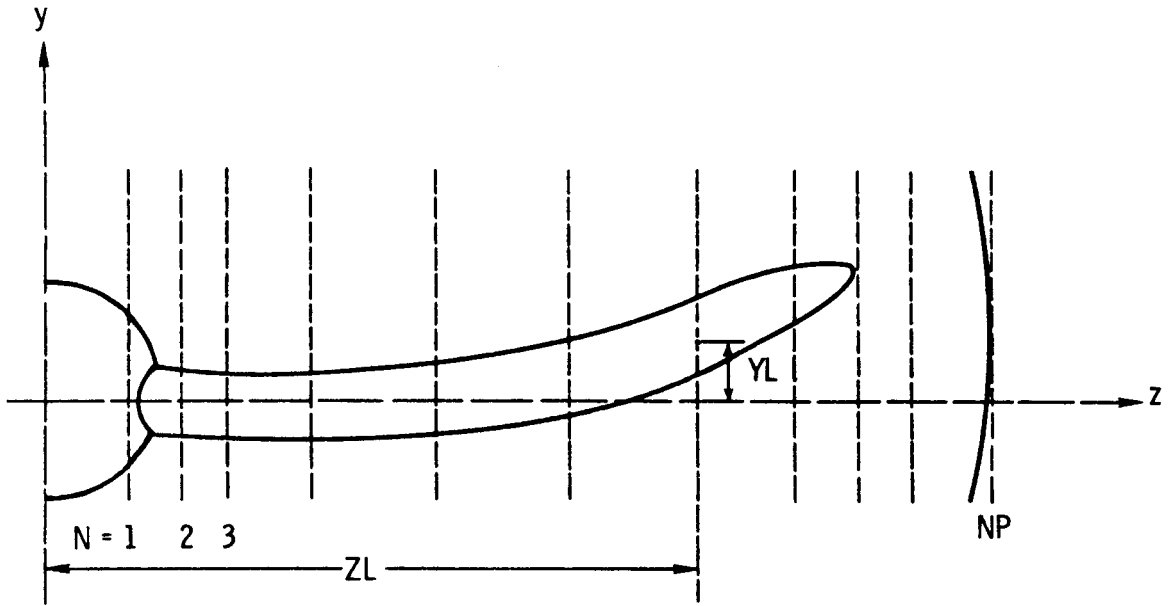

Figure 10. – Input planes and corresponding input parameters.

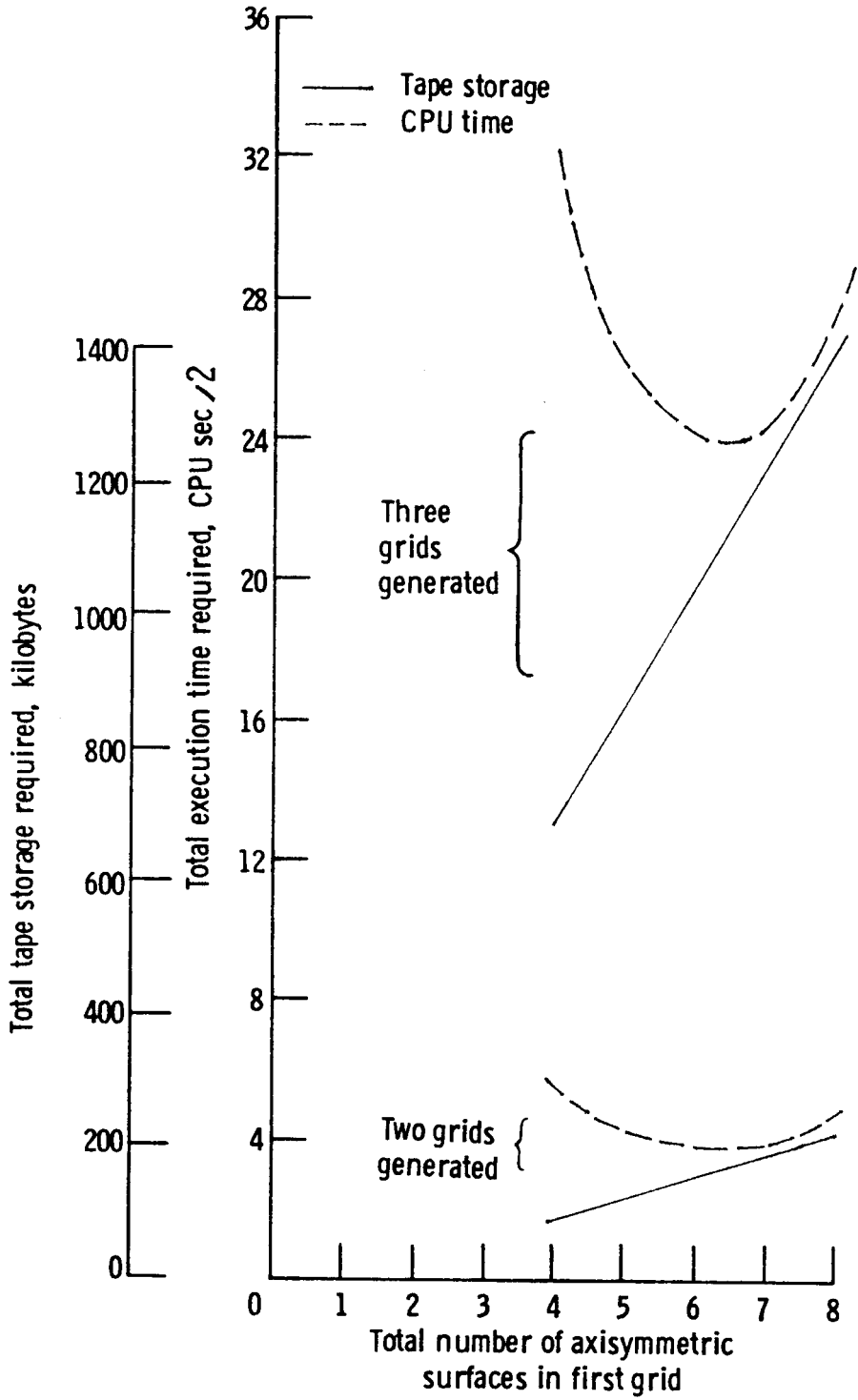

Figure 11. -- Computer requirements and GRID3C performance charts as evaluated on an IBM 370/3033 computer.

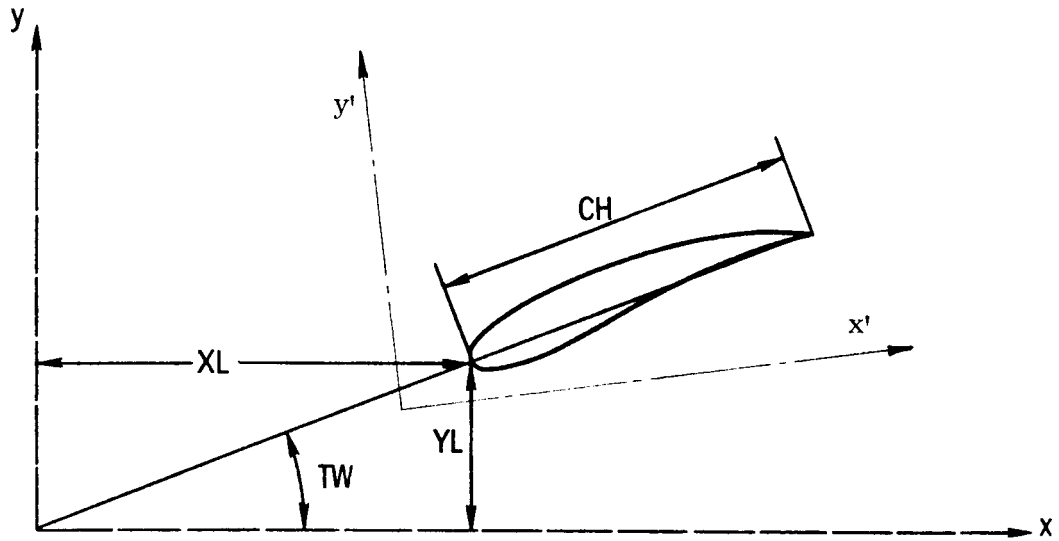

Figure 12. – Relation between the global (x,y,z) coordinate system and the input (x',y',z) coordinate system.

-0.0011160	-0.0032200	-0.0046540	-0.0053530	-0.0052970	-0.0023880	-0.0001040	0.0033080	
0.0080300	0.0134560	0.0183020	0.0265780	0.0360130	0.0470300	0.0585820	0.0697400	
0.0833440	0.0952580	0.1102530	0.1135040	0.1201700	0.1323500	0.1444229	0.1563359	
0.1680509	0.1795400	0.1907830	0.2017710	0.2124990	0.2229670	0.2331760	0.2431340	
0.2528480	0.2623270	0.2715780	0.2806120	0.2894390	0.2980680	0.3065079	0.3147700	
0.3228610	0.3307910	0.3385680	0.3462000	0.3536940	0.3610590	0.3683000	0.3754250	
0.3824400	0.3893520	0.3961660	0.4028870	0.4095220	0.4160759	0.4225529	0.4289590	
0.4352990	0.4415759	0.4477950	0.4539610	0.4600770	0.4661469	0.4721749	0.4781650	
0.4841190	0.4900420	0.4959350	0.5018020	0.5076440	0.5134650	0.5192650	0.5250460	
0.5308100	0.5365559	0.5422850	0.5479960	0.5536870	0.5593550	0.5649990	0.5706120	
0.5761890	0.5817220	0.5872000	0.5926120	0.5979420	0.6031710	0.6082780	0.6132350	
0.6180090	0.6225600	0.6268440	0.6308030	0.6343750	0.6374850	0.6400470	0.6419100	
0.6427870	0.0000000	0.0000000	0.0000000	0.0000000	0.0000000	0.0000000	0.0000000	
0.7660440	0.7650840	0.7632050	0.7602940	0.7563200	0.7511790	0.7447630	0.7369699	
0.7277229	0.7169760	0.7047279	0.6910320	0.6759970	0.6597900	0.6426240	0.6247420	
0.6064060	0.5878699	0.5693690	0.5511060	0.5332450	0.5159100	0.4991879	0.4831300	
0.4677629	0.4530900	0.4391000	0.4257700	0.4130700	0.4009640	0.3894160	0.3783880	
0.3678440	0.3577480	0.3480650	0.3387650	0.3298160	0.3211910	0.3128639	0.3048109	
0.2970090	0.2894379	0.2820790	0.2749130	0.2679260	0.2611000	0.2544230	0.2478810	
0.2414620	0.2351540	0.2289450	0.2228280	0.2167900	0.2108240	0.2049220	0.1990750	
0.1932750	0.1875160	0.1817900	0.1760920	0.1704150	0.1647540	0.1591030	0.1534570	
0.1478110	0.1421630	0.1365060	0.1308399	0.1251600	0.1194650	0.1137519	0.1080250	
0.1022760	0.0965130	0.0907370	0.0849510	0.0791600	0.0733730	0.0675990	0.0618490	
0.0561380	0.0504840	0.0449090	0.0394400	0.0341060	0.0289450	0.0239980	0.0193130	
0.0149490	0.0109690	0.0074450	0.0044550	0.0020860	0.0004150	-0.0004820	-0.0004990	
0.0007290	0.0034250	0.0075520	0.0131460	0.0203070	0.0366890	0.0446900	0.0553690	
0.0687820	0.0830480	0.0951130	0.1146520	0.1357250	0.1591130	0.1825170	0.2041309	
0.2291909	0.2499580	0.2741500	0.2789820	0.2887149	0.3058630	0.3223030	0.3380330	
0.3530660	0.3674240	0.3811359	0.3942320	0.4067490	0.4187199	0.4301810	0.4411629	
0.4516979	0.4618170	0.4715469	0.4809150	0.4899440	0.4986570	0.5070740	0.5152150	
0.5230970	0.5307370	0.5381500	0.5453489	0.5523480	0.5591590	0.5657920	0.5722580	
0.5785660	0.5847260	0.5907460	0.5966330	0.6023960	0.6080400	0.6135730	0.6190000	
0.6243260	0.6295580	0.6346999	0.6397570	0.6447330	0.6496330	0.6544590	0.6592150	
0.6639040	0.6685300	0.6730940	0.6775990	0.6820469	0.6864390	0.6907760	0.6950600	
0.6992900	0.7034670	0.7075880	0.7116530	0.7156600	0.7196060	0.7234859	0.7272969	
0.7310320	0.7346830	0.7382420	0.7416970	0.7450370	0.7482640	0.7513010	0.7541870	
0.7568750	0.7593369	0.7615350	0.7634300	0.7649730	0.7660980	0.7667470	0.7666570	
0.7660440	0.0000000	0.0000000	0.0000000	0.0000000	0.0000000	0.0000000	0.0000000	
1.85000	0.00000	0.00000	0.23125	34.50000	-0.00111	0.00073	0.64278	0.76604193
1.90000	0.00000	0.00000	0.23750	35.50000	-0.00111	0.00073	0.64278	0.76604193
1.95000	0.00000	0.00000	0.24375	36.20000	-0.00111	0.00073	0.64278	0.76604193
2.00000	0.00000	0.00000	0.25000	37.00000	-0.00111	0.00073	0.64278	0.76604193
2.10000	0.00000	0.00000	0.26250	38.20000	-0.00111	0.00073	0.64278	0.76604193

Figure 13. – An input example describing geometry of a forty-blade ducted rotor with a linear spanwise blade chord variation. The blade is composed of two airfoil shapes.

3-D MULTILEVEL BOUNDARY-CONFORMING PERIODIC GRIDS
 ("C"-TYPE GRID)
 NASA LEWIS COMPUTATIONAL FLUID MECHANICS BRANCH
 (GRID3C) DEVELOPED BY: DJORDJE S. DULIKRAVICH
 =====

INPUT PARAMETERS

FOURTY-BLADE ROTOR IN A CYLINDRICAL DUCT : INPUT FOR (GRID3C)

NB	NX	NY	NZ	NT	NH	ND	NP	NG	NC	
40	24	6	6	6	10	10	10	3	1	
XX	YY	ZZ	DZ	RT	SA	XE				
1.150	1.000	0.500	1.000	2.000	0.000	1.500				
XHUB(I)	RHUB(I)	XDUCT(I)	RDUCT(I)	I						
-0.900000E 01	0.100000E 01	-0.900000E 01	0.200000E 01	1						
-0.700000E 01	0.100000E 01	-0.700000E 01	0.200000E 01	2						
-0.400000E 01	0.100000E 01	-0.400000E 01	0.200000E 01	3						
-0.400000E 00	0.100000E 01	-0.400000E 00	0.200000E 01	4						
0.000000	0.100000E 01	0.000000	0.200000E 01	5						
0.200000E 00	0.100000E 01	0.200000E 00	0.200000E 01	6						
0.500000E 00	0.100000E 01	0.500000E 00	0.200000E 01	7						
0.100000E 01	0.100000E 01	0.100000E 01	0.200000E 01	8						
0.500000E 01	0.100000E 01	0.500000E 01	0.200000E 01	9						
0.125000E 02	0.100000E 01	0.125000E 02	0.200000E 01	10						
ZL	XL	YL	CH	TW	XS1	YS1	XS2	YS2	IPNT	N
0.75000	0.00000	0.00000	-0.09375	8.00000	-0.00025	-0.00288	0.89100	0.45399	193	1
0.90000	0.00000	0.00000	0.11250	12.00000	-0.00025	-0.00288	0.89100	0.45399	193	2
1.10000	0.00000	0.00000	0.13750	16.80000	-0.00025	-0.00288	0.89100	0.45399	193	3
1.25000	0.00000	0.00000	0.15625	21.50000	-0.00025	-0.00288	0.89100	0.45399	193	4
1.80000	0.00000	0.00000	-0.22500	33.00000	-0.00111	0.00073	0.64278	0.76604	193	5
1.85000	0.00000	0.00000	0.23125	34.50000	-0.00111	0.00073	0.64278	0.76604	193	6
1.90000	0.00000	0.00000	0.23750	35.50000	-0.00111	0.00073	0.64278	0.76604	193	7
1.95000	0.00000	0.00000	0.24375	36.20000	-0.00111	0.00073	0.64278	0.76604	193	8
2.00000	0.00000	0.00000	0.25000	37.00000	-0.00111	0.00073	0.64278	0.76604	193	9
2.10000	0.00000	0.00000	0.26250	38.20000	-0.00111	0.00073	0.64278	0.76604	193	10

OUTPUT PARAMETERS

ZLEAD	XLEAD	YLEAD	CHORD	TWIST	K
1.000000	-0.000000	0.000000	0.125039	14.084403	2
NTAPE=13	MAXXP=147	MAXYP= 27			
NTAPE=12	MAXXP= 75	MAXYP= 15			
NTAPE=11	MAXXP= 39	MAXYP= 9			
1.021070	-0.000000	0.000000	0.127668	14.571881	3
NTAPE=13	MAXXP=147	MAXYP= 27			
1.043544	-0.000000	0.000000	0.130459	15.111949	4
NTAPE=13	MAXXP=147	MAXYP= 27			
NTAPE=12	MAXXP= 75	MAXYP= 15			
1.068729	-0.000000	0.000000	0.133571	15.751108	5
NTAPE=13	MAXXP=147	MAXYP= 27			
1.097750	-0.000000	0.000000	0.137140	16.545509	6
NTAPE=13	MAXXP=147	MAXYP= 27			
NTAPE=12	MAXXP= 75	MAXYP= 15			
NTAPE=11	MAXXP= 39	MAXYP= 9			
1.131467	-0.000000	0.000000	0.141272	17.557668	7
NTAPE=13	MAXXP=147	MAXYP= 27			
1.170422	-0.000000	0.000000	0.146071	18.802124	8
NTAPE=13	MAXXP=147	MAXYP= 27			
NTAPE=12	MAXXP= 75	MAXYP= 15			
1.214800	-0.000000	0.000000	0.151616	20.226947	9
NTAPE=13	MAXXP=147	MAXYP= 27			
1.264417	-0.000000	0.000000	0.157941	21.700360	10
NTAPE=13	MAXXP=147	MAXYP= 27			
NTAPE=12	MAXXP= 75	MAXYP= 15			
NTAPE=11	MAXXP= 39	MAXYP= 9			
1.318729	-0.000000	0.000000	0.164975	23.076824	11
NTAPE=13	MAXXP=147	MAXYP= 27			
1.376878	-0.000000	0.000000	0.172533	24.326576	12
NTAPE=13	MAXXP=147	MAXYP= 27			
NTAPE=12	MAXXP= 75	MAXYP= 15			
1.437737	-0.000000	0.000000	0.180381	25.464125	13
NTAPE=13	MAXXP=147	MAXYP= 27			

1.499999	-0.000000	0.000000	0.188278	26.530720	14
NTAPE=13	MAXXP=147	MAXYP= 27			
NTAPE=12	MAXXP= 75	MAXYP= 15			
NTAPE=11	MAXXP= 39	MAXYP= 9			
1.562263	-0.000000	0.000000	0.196004	27.582174	15
NTAPE=13	MAXXP=147	MAXYP= 27			
1.623121	-0.000000	0.000000	0.203393	28.673013	16
NTAPE=13	MAXXP=147	MAXYP= 27			
NTAPE=12	MAXXP= 75	MAXYP= 15			
1.681270	-0.000000	0.000000	0.210338	29.841808	17
NTAPE=13	MAXXP=147	MAXYP= 27			
1.735582	-0.000000	0.000000	0.216787	31.101078	18
NTAPE=13	MAXXP=147	MAXYP= 27			
NTAPE=12	MAXXP= 75	MAXYP= 15			
NTAPE=11	MAXXP= 39	MAXYP= 9			
1.785199	-0.000000	0.000000	0.222731	32.435393	19
NTAPE=13	MAXXP=147	MAXYP= 27			
1.829577	-0.000000	0.000000	0.228173	33.785928	20
NTAPE=13	MAXXP=147	MAXYP= 27			
NTAPE=12	MAXXP= 75	MAXYP= 15			
1.868532	-0.000000	0.000000	0.233027	34.831096	21
NTAPE=13	MAXXP=147	MAXYP= 27			
1.902249	-0.000000	0.000000	0.237211	35.457179	22
NTAPE=13	MAXXP=147	MAXYP= 27			
NTAPE=12	MAXXP= 75	MAXYP= 15			
NTAPE=11	MAXXP= 39	MAXYP= 9			
1.931270	-0.000000	0.000000	0.240820	35.868062	23
NTAPE=13	MAXXP=147	MAXYP= 27			
1.956455	-0.000000	0.000000	0.243950	36.216503	24
NTAPE=13	MAXXP=147	MAXYP= 27			
NTAPE=12	MAXXP= 75	MAXYP= 15			
1.978929	-0.000000	0.000000	0.246740	36.568690	25
NTAPE=13	MAXXP=147	MAXYP= 27			
2.000000	-0.000000	0.000000	0.249360	36.910523	26
NTAPE=13	MAXXP=147	MAXYP= 27			
NTAPE=12	MAXXP= 75	MAXYP= 15			
NTAPE=11	MAXXP= 39	MAXYP= 9			

(X,Y,Z) COORDINATES OF (147*27*25) = 99225 POINTS WRITTEN ON UNIT 13

(X,Y,Z) COORDINATES OF (75*15*13) = 14625 POINTS WRITTEN ON UNIT 12

(X,Y,Z) COORDINATES OF (39* 9* 7) = 2457 POINTS WRITTEN ON UNIT 11

Figure 14. – Output from GRID3C corresponding to the input given in figure 13.

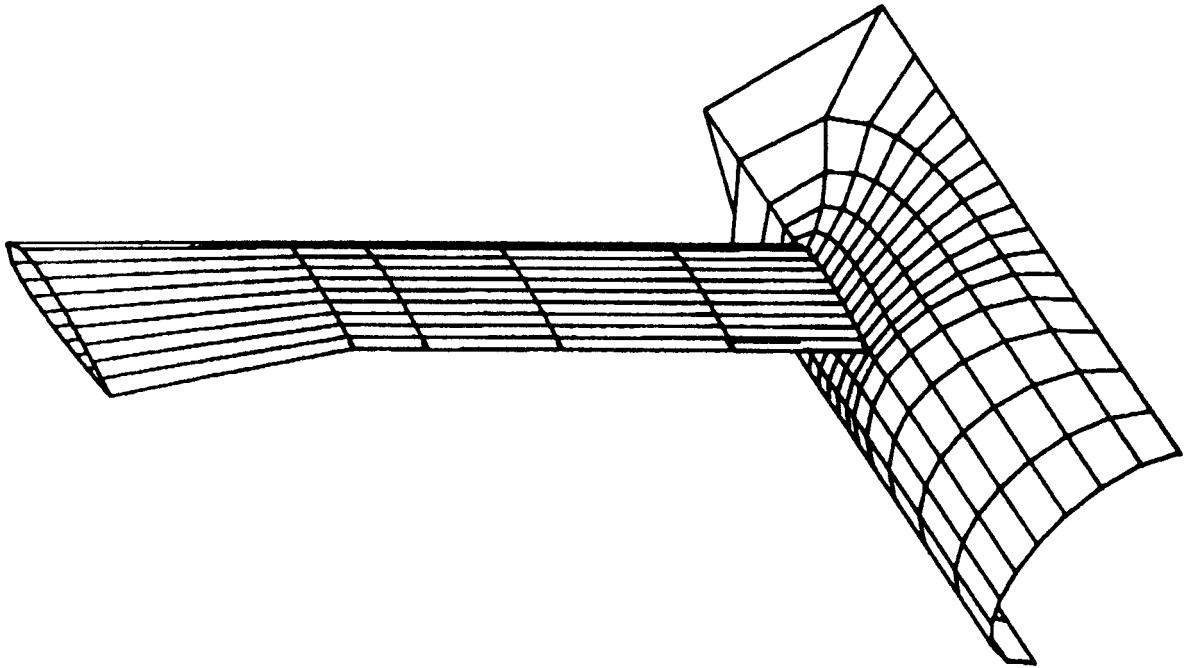

Figure 15. – Key elements of a three-dimensional C-type grid generated by GRID3C code with the input given in figure 8. Note the grid deterioration in the upstream region. This can be improved by modifying parts of the main program and the subroutine XYZINF.

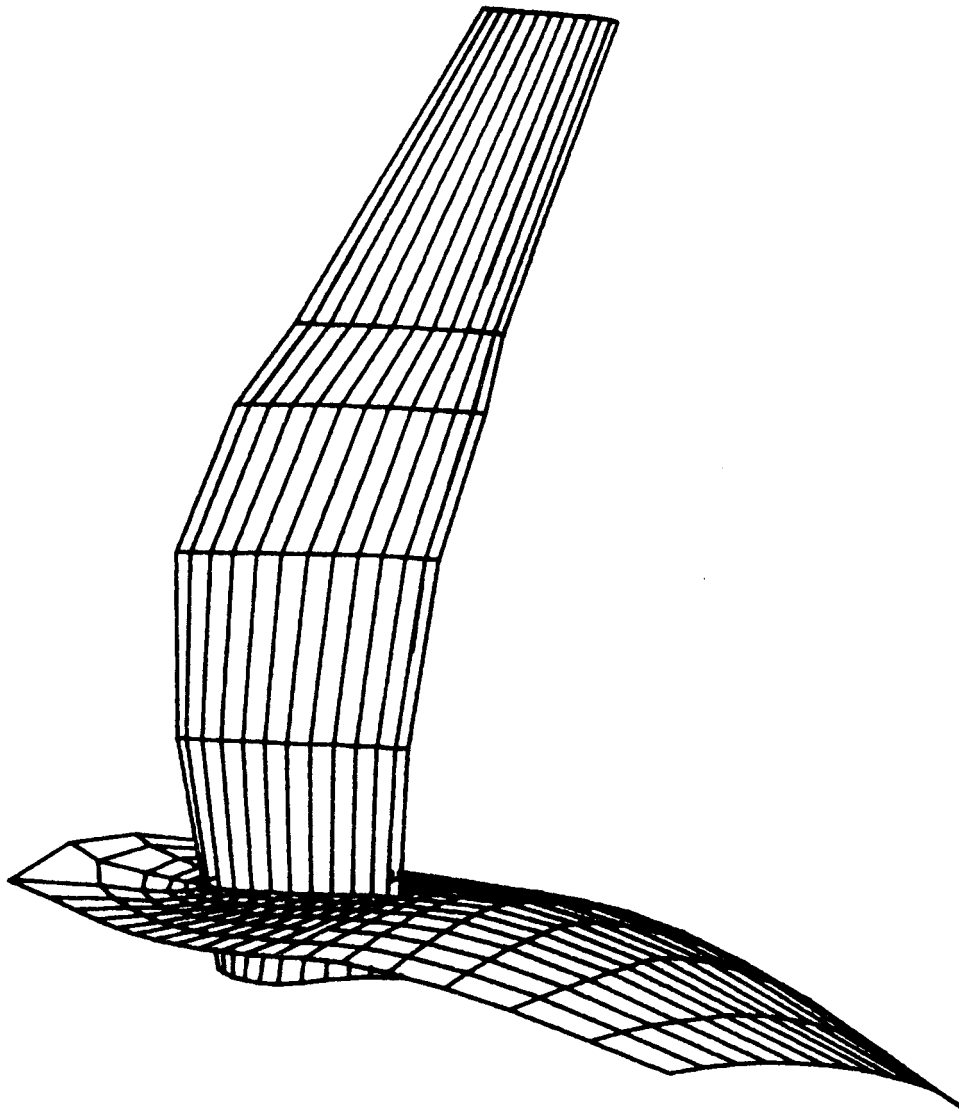

Figure 16. – Parts of a three-dimensional C-type grid generated by GRID3C code for an advanced eight-blade NASA prop-fan. Note significant spanwise variations of blade sweep angle and chord length. Note also that the hub surface is axisymmetric.

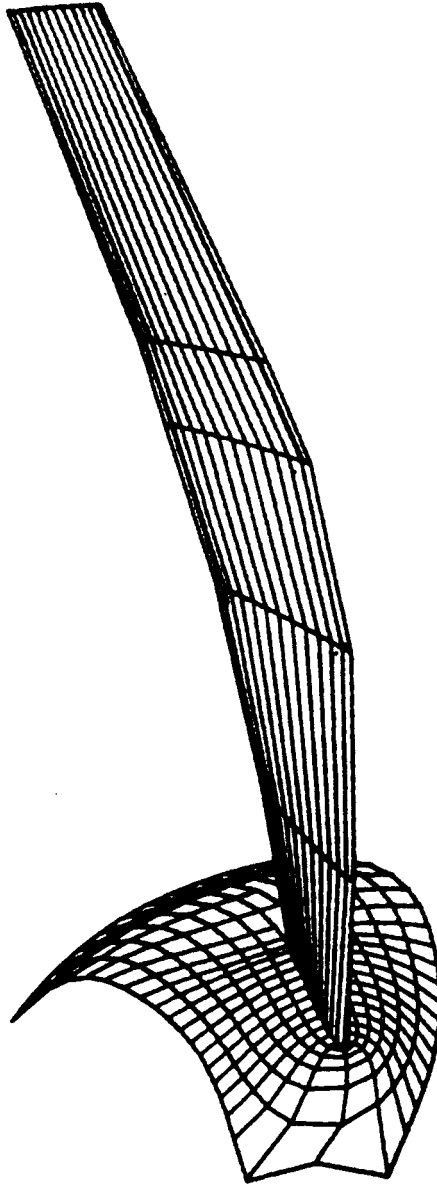

Figure 17. – View of figure 16 from a different angle revealing the helicoidal shape of the periodic strip on the hub surface. Note the significant spanwise variation of the blade twist angle.

1. Report No. NASA CR-167846		2. Government Accession No.		3. Recipient's Catalog No.	
4. Title and Subtitle GRID3C - COMPUTER PROGRAM FOR GENERATION OF C-TYPE MULTILEVEL, THREE-DIMENSIONAL BOUNDARY- CONFORMING PERIODIC GRIDS				5. Report Date March 1982	
				6. Performing Organization Code	
7. Author(s) Djordje S. Dulikravich				8. Performing Organization Report No. None	
9. Performing Organization Name and Address Universities Space Research Association American City Building, Suite 311 Columbia, Maryland 21044				10. Work Unit No.	
				11. Contract or Grant No. NAS3-22532	
12. Sponsoring Agency Name and Address National Aeronautics and Space Administration Washington, D. C. 20546				13. Type of Report and Period Covered Contractor Report	
				14. Sponsoring Agency Code 505-32-52	
15. Supplementary Notes Final report. Project Manager, John J. Adamczyk, Fluid Mechanics and Acoustics Division, NASA Lewis Research Center, Cleveland, Ohio 44135.					
16. Abstract A fast computer program, GRID3C, has been developed for accurately generating periodic, boundary-conforming, three-dimensional, consecutively refined computational grids applicable to realistic axial turbomachinery geometries. The method is based on using two functions to generate two-dimensional grids on a number of coaxial axisymmetric surfaces positioned between the centerbody and the outer radial boundary. These boundary fitted grids are of the C-type and are characterized by quasi-orthogonality and geometric periodicity. The built-in nonorthogonal coordinate stretchings and shearings cause the grid clustering in the regions of interest. The stretching parameters are part of the input to GRID3C. In its present version GRID3C can generate and store a maximum of four consecutively refined three-dimensional grids. The output grid coordinates can be calculated either in the Cartesian or in the cylindrical coordinate system.					
17. Key Words (Suggested by Author(s)) Grid generation Turbomachinery Computational grids Geometry Numerical methods Conformal mapping			18. Distribution Statement Unclassified - unlimited STAR Category 02		
19. Security Classif. (of this report) Unclassified		20. Security Classif. (of this page) Unclassified		21. No. of Pages 26	22. Price*